

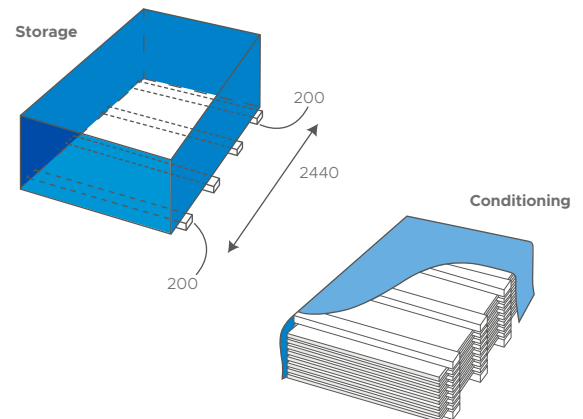

Storage

All Customwood® MDF panels must be stored in a dry, covered area.

- Provide well-ventilated storage away from moisture, heat and direct sunlight.
- Place 75 mm gluts on a dry, level floor ensuring they run the full width of the pack.
- When stacking, position packs so the gluts line up vertically one above the other.
- Place end gluts 200 mm from each end.
- Intermediate gluts to be spaced evenly. The number of gluts will vary according to pack length, as follows;



Thin Panel	1241-1980	3 gluts
	1981-2450	4 gluts
	2451-3800	5 gluts

Note: (1) Where atmospheric changes have caused sheet distortion, it is recommended that the pack bands be cut and a minimum conditioning period of 48 hours be allowed before use.
(2) If extreme damp or dry storage conditions are expected products should be covered with breather type sheeting. (Refer Conditioning).

Safe work practices

As a reconstituted panel product made from wood, resin and wax, users should be aware that as with all wood and timber products, exposure to wood dust and/or formaldehyde from Customwood MDF may irritate the eyes, respiratory system and skin. Inhalation may result in asthma and skin contact may cause dermatitis. As a known carcinogen, repeated inhalation of wood dust over many years may cause nasal cancer. Formaldehyde is also classified as a known carcinogen. Formaldehyde is used in the production of the resin which acts as a bonding agent in manufacture of wood products such as MDF, Particleboard, Triboard and Strandboard. Formaldehyde-based resins are also commonly used in other household products including carpets and draperies.

Work and storage areas should be well ventilated, and cleaned regularly. Wood dust should be removed by vacuum cleaning or by the wet sweeping method – not by compressed air systems. If skin irritations occur, long-sleeved shirts, trousers and comfortable work gloves should be worn. For respiratory protection, respirators/dust masks should be worn. These should comply with AS/NZS 1716. For more information refer to the Product Safety Card and the FAQ on dust and formaldehyde.

Performance

Conditioning

All wood and wood-based sheet materials shrink or swell with changes in moisture content.

The moisture content of Customwood® MDF Panels at the time of delivery to the end user may differ from when the product was manufactured. In particular, some absorption of moisture is inevitable during long periods in damp storage conditions such as building sites, and a loss of moisture is likely in dry conditions.

These changes will initially affect the exposed edges and the top layers of stacked boards but will eventually extend to all boards in a pack. To ensure dimensional stability, condition the product for 48 hours prior to installation in atmospheric conditions as close as possible to those of the final end use.

To assist air movement around sheets:

- insert gluts between each sheet
- support each sheet as per diagram.

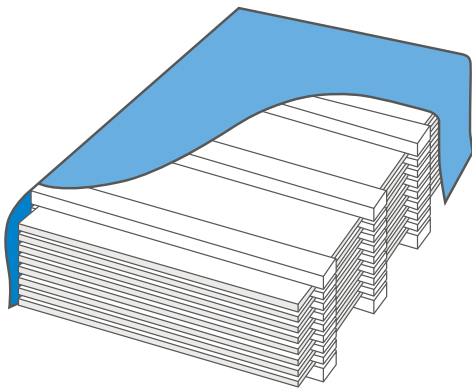

Durability

When used where occasional wetting is expected (kitchen, laundry, bathrooms), the edges of Customwood® MDF Panel must be protected with a water-resistant overlay or paint system with a low water vapour permeability. Durability in these situations depends on the integrity of the finish being maintained.

Any damage to these surface coatings must be immediately repaired to maintain their waterproof capability.

Limitations of Use

Customwood® MDF Panel Products **MUST NOT** be used in the following situations;

- Exterior applications.
- Windows (sills, jambs and heads).
- Roof or wall sarking materials.
- Wall linings directly in contact or in close proximity to urinals, showers, baths, saunas, spas and swimming pools.
- Backing to exterior or interior solid plaster systems.
- As a wall or ceiling lining in biologically sterile areas in laboratories.
- Flooring panels.
- Close to heat sources where panel surface temperature exceeds 50C.
- In direct contact with concrete or masonry surfaces unless separated by a Damp Proof Course.

Fungal and Insect Resistance

No fungicides or insecticides are added to Customwood® MDF Panels during manufacture. Fungal growth will not occur unless panel moisture content rises to levels which would have an adverse effect on the panel properties.



DAIKEN
NEW ZEALAND LIMITED



0800 369 633
info@customwood.co.nz
www.customwood.co.nz